

Robotics in Africa Forum at IROS 2024



16th October 2024

Behavior Trees for Culturally Sensitive Social Robots: African Culture Case Study

Ibrahim Jimoh, Heran Equbay, Clifford Onyonka, Tsegazeab Tefferi, & David Vernon

Carnegie Mellon University Africa

www.africa.engineering.cmu.edu



Robot Mission Implementation

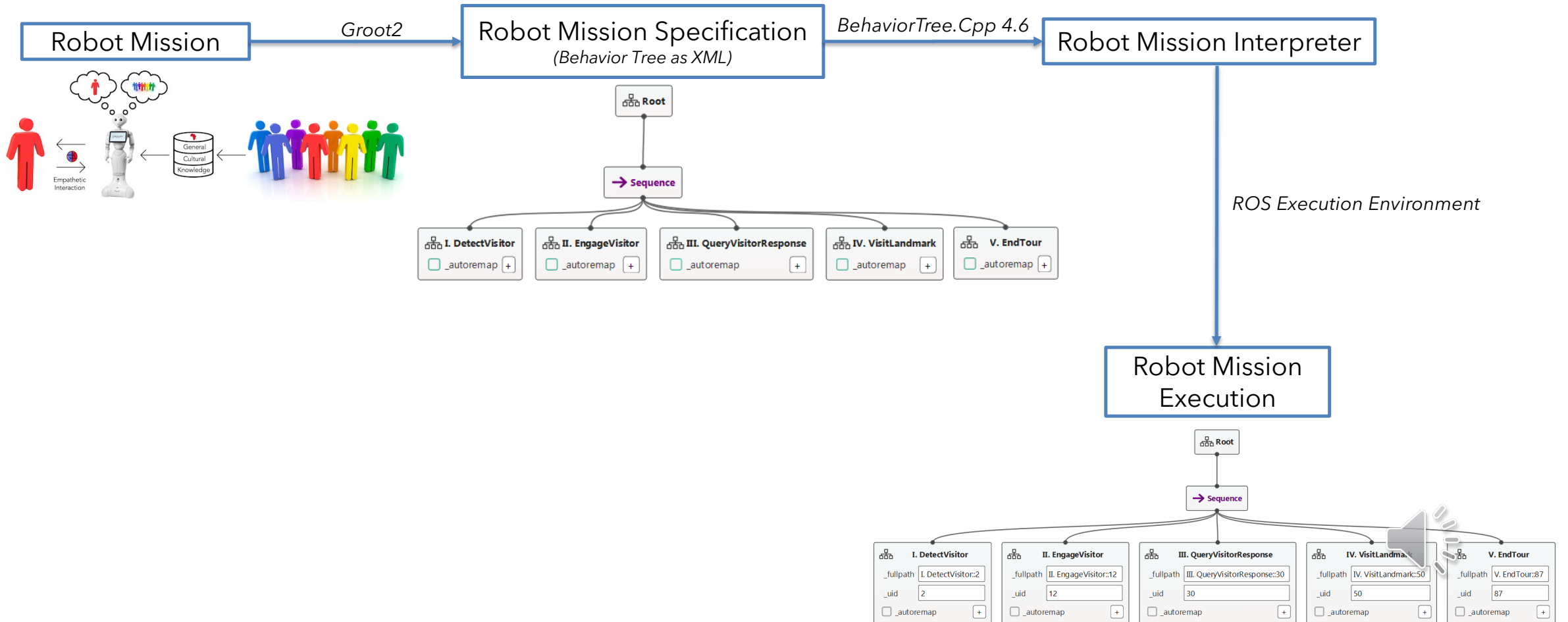

CSSR4Africa System Architecture

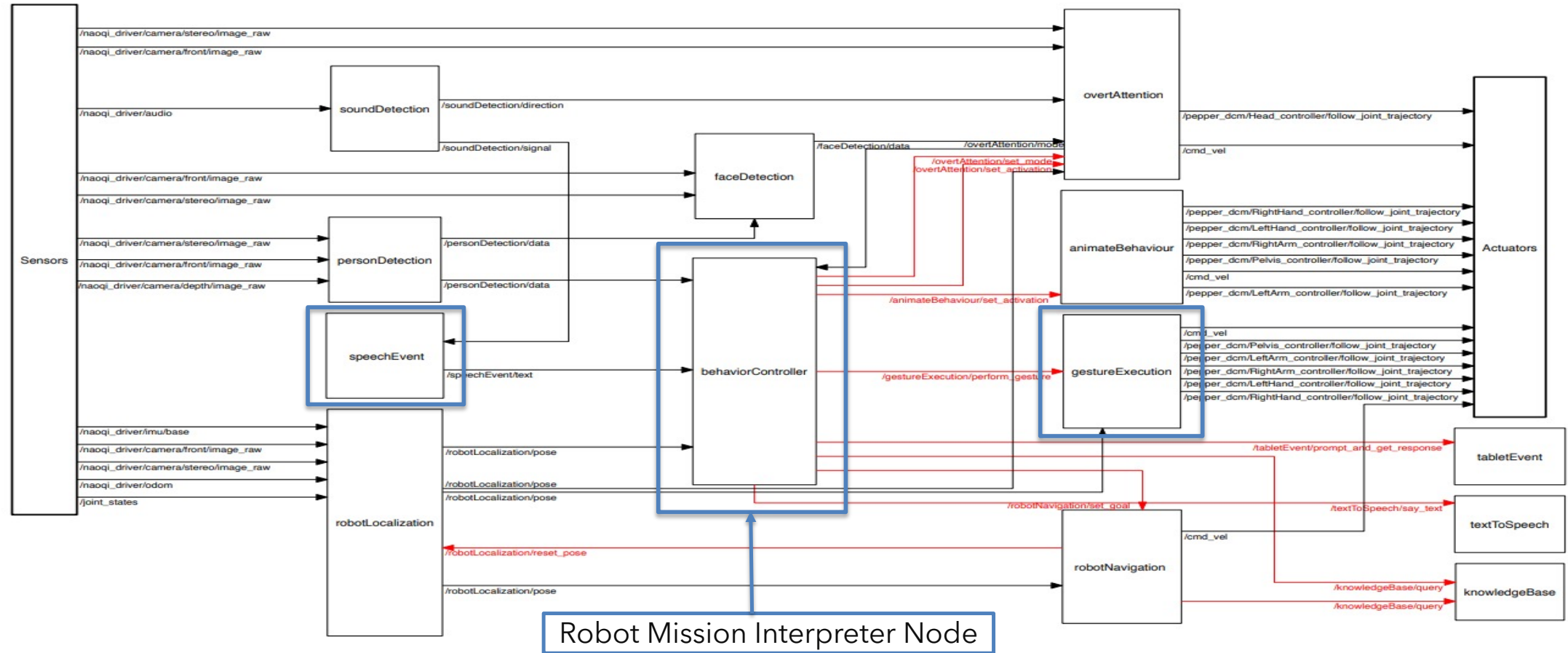

References:

- R. Ghzouli, T. Berger, E. B. Johnsen, A. Wasowski and S. Dragule, "Behavior Trees and State Machines in Robotics Applications," in IEEE Transactions on Software Engineering, vol. 49, no. 9, pp. 4243-4267, Sept. 2023, doi: 10.1109/TSE.2023.3269081.
- B. Bruno, C. T. Recchiuto, I. Papadopoulos, A. Saffiotti, C. Koulouglioti, R. Menicatti, F. Mastrogiovanni, R. Zaccaria, and A. Sgorbissa, "Knowledge representation for culturally competent personal robots: requirements, design principles, implementation, and assessment", International Journal of Social Robotics, vol. 11, no. 3, pp. 515-538, 2019
- D. Faconti and M. Colledanchise, "BehaviorTree.CPP library documentation," <https://www.behaviortree.dev>, 2018.
- D. Faconti and M. Colledanchise, "BehaviorTree.CPP library tutorials," <https://www.behaviortree.dev/tutorial01firsttree/>, 2018.
- D. Faconti. 2019. "BehaviorTree.CPP library". <https://github.com/BehaviorTree/BehaviorTree.CPP>

